

Electronic coin validator G-13.mft cctalk (from model /4 on)

Operating instructions

12.05 Hns/ds
Edition 1.2
BA.G13MFTCCT-GB

Table of contents

1	General information	7
	General information about these instructions	7
	General information about the coin validator G-13.mft with cctalk interface	8
	Advantages	9
	Models	9
2	Safety instructions	10
	Proper use	10
	Protecting yourself and equipment	11
3	Design	12
	Switching blocks	14
	Switch assignment with double block data-management (B-0 and B-1)	14
	Switch assignment with single block data-management	15
	Return lever and return button	15
	Interfaces	16
	Interface – vending machine	16
	Interface – configuration (WinEMP/PalmEMP2)	16
	Interface – external sorting device	17
	Label	17

4	Function	18
	Coin acceptance and coin rejection	18
	Coin channels	19
	Single or double block data-management	20
	Accepted coin sensors	20
	Control for external sorting of accepted coins	21
	Sorting principle	21
	Sorting with NRI sorting device	22
	Sorting time of an external sorting device	23
	Do not accept coin types	23
	Inhibit all/individual coin types via vending machine control system	23
	Inhibit individual coin types/coin type groups on the coin validator	23
5	Starting up	24
	Starting up in the vending machine	25
	Device environment for configuration software WinEMP	26
	Connection to Palm handheld (PalmEMP2)	27
	Installation of the NRI sorting device	28
6	Operation	30
	Inhibit coin channels ...	30
	... with double block data-management (B-0 and B-1)	30
	... with single block data-management	32
	Teach mode	34
	Switch assignment with double block data-management (in teach mode)	34
	Switch assignment with single block data-management (in teach mode)	34
	Teach coin channels	35
	Select memory block (only for double block data-management)	36

7	Maintenance and service	37
	Cleaning coin validator	37
	Troubleshooting	38
8	Which functions can be set using WinEMP/ PalmEMP2?	39
9	Technical data	40
	CE certification	41
	Pin assignment	42
	G-13.mft – vending machine	42
	G-13.mft – external sorting device	42
	Commands, status and error messages	43
	Implemented cctalk commands	43
	Buffered error code table	44
	Standard settings (following reset)	45
	Accessories	46
	Front plates	46
	Sorting device	47
	Configuration software	48
	Index	49
	Glossary	52



1 General information

This chapter should provide a general overview of the advantages and options regarding the coin validator G-13.mft with serial cctalk interface. The first section, however, is designed to help you navigate easily within these operating instructions.

General information about these instructions

These operating instructions describe the design and operation of the electronic coin validator G-13.mft with cctalk interface. Chapters 5 and 6 explain the necessary steps for starting up and operating the coin validator. The index and glossary shorten the search for specific explanations.

To make it easier for you to navigate within these instructions and to operate the device, the following accentuations were made in the text:

- **Safety instructions**, which have to be taken note of in order to protect operators and equipment, have been written in bold and given the pictogram .
- Special *notes*, which are to facilitate the use of the coin validator, have been written in italics and also been given a pictogram .
- **Requests to perform an action** are numbered in another typeface.
- At the beginning of a chapter you will find a short "guide", which summarizes the content of the chapter.

Apart from these operating instructions there is the following technical documentation for the G-13.mft with cctalk interface:

- WinEMP – The configuration and diagnostics program for NRI coin validators, operating instructions for the G-13.mft
- PalmEMP2 – Operating instructions for configuration of the coin validator G-13.mft
- Tester G-19.0641
- Electronic coin validator G-13.mft – Mounting dimensions



If this documentation is not available to you, it can be downloaded at any time from the NRI homepage (www.nri.de) in a compressed PDF format.

General information about the coin validator G-13.mft with cctalk interface

The electronic coin validator G-13.mft (Multi-frequency technology) in standardized 3 1/2" format is based on the tried and tested features of the G-13.6000. Due to its modular and compact design, the G-13.mft is ideally suited for amusement, vending and service machines.

The **multi-frequency technology** is new in the G-13.mft. It provides more flexibility for the measuring sensors, multiple scanning of the coins inserted for optimum material recognition and evaluation of 24 measuring parameters for reliable acceptance of genuine coins and separating out of false coins. Thanks to the coin validator's **flash technology** software downloads to adapt the measuring technology, coin data and control software can be executed quickly and simply. The G-13.mft has 32 coin channels that can be data-managed, starting from device version /4 and higher, either in a single memory block or, when divided in 2 x 16 coin channels, in two memory blocks with different coin configurations.

To be able to react as quickly as possible to new false coins and to enable you to make your individual adjustments, the coin validator can be connected to a PC programming station which is made up of the configuration and diagnostics software "WinEMP" including card reader and the tester G-19.0641. With the aid of the Palm handheld software "PalmEMP2" you can configure the coin validator directly at the machine independently of the PC.



To ensure that the injunctions of the Italian amusement machine law "legge 289 – comma 6" are observed, the cctalk ACMI model of the G-13.mft is not allowed to be configured.

Please contact NRI if you want to change the factory settings.

Coins that have not been taken into consideration at the manufacturer's company can be programmed in the optional teach mode directly at the coin validator by inserting coins.

Advantages

- Acceptance speed of 2 coins per second
- Coin channels that can be inhibited individually or in groups
- Teach mode for 8 coin channels
- Operating and manipulation safety thanks to optical accepted coin sensors and sorting control in coin outlet area
- Interface for connection to a programming station or Palm handheld which makes immediate reaction to the use of false coins possible
- Multi-frequency technology for reliable coin recognition
- Flash technology for uncomplicated and time-saving firmware updates
- Optional sensor for increased protection against manipulation in the cash-box chute

Models

The G-13.mft with cctalk interface is available as a standard model and as a cctalk ACMI model. The latter model fulfils all requirements of the Italian amusement machine law "legge 289 – comma 6", which was passed in July 2003.



To ensure that the injunctions of the Italian amusement machine law are observed, subsequent configuration of the cctalk ACMI model of the G-13.mft is not possible.

Please contact NRI if you want to change the factory settings.

Both models are available with top or front entry. The G-13.mft with front entry usually has a MIDI front plate or a MINI front plate fitted to the left-hand side of the device (see Chap. 3 "Design"). The device is, however, also available as a front entry model without front plate.

2 Safety instructions

Before operating the device for the first time, please read through these instructions carefully at least once, and most importantly the safety instructions. This is to ensure you have understood the contents of these instructions as well as how to operate the coin validator.

Proper use

Series G-13.mft coin validators with cctalk interface are intended to be used in amusement, vending and service machines with a cctalk interface and are supposed to check the coins inserted in the machines for specific coin properties.

These coin validators have been constructed in compliance with the state of the art and recognized safety regulations. Nevertheless this equipment can be a source of danger. Therefore please observe the following safety regulations.

Protecting yourself and equipment



The coin validator may only be connected by a qualified electrician.

Only use the coin validator according to proper use. Under no circumstances can the manufacturer be held liable for any damage or loss resulting from improper use of the device.

The coin validator PCB is fitted with components which may be damaged beyond repair by electrostatic discharge. Please observe the handling instructions for components exposed to the risk of electrostatic discharge.

Pull out the vending machine's mains plug before you install, clean or remove the coin validator.

Select the correct voltage for the coin validator (see label).

Ensure the correct potential equalization in the vending machine.

Never pull the connecting cable of the coin validator from the vending machine when a voltage is applied.

Contact NRI if you wish to alter the construction of the device to a greater extent than that described in these instructions.

Keep water and other liquids away from the coin validator.

If the device is no longer required, please dispose of it correctly.

We reserve the right to make technical modifications to the device which are not covered by these instructions.

3 Design

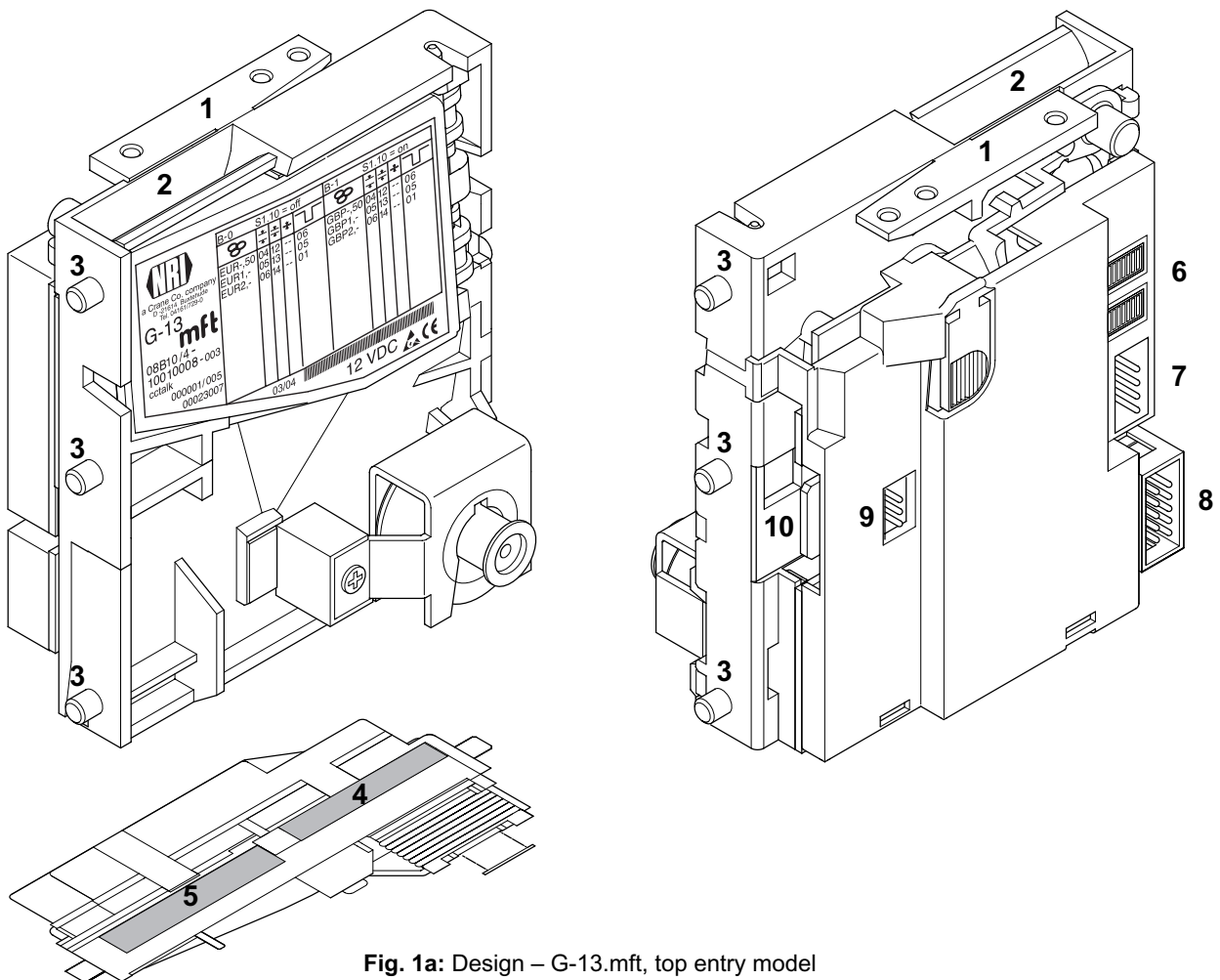

Fig. 1a: Design – G-13.mft, top entry model

- 1 Return lever
- 2 Coin insert funnel
- 3 Mounting studs
- 4 Coin outlet – return area
- 5 Coin outlet – cash-box
- 6 Switching blocks
- 7 cctalk interface – vending machine
- 8 Interface – external sorting
- 9 Interface – external sorting for other protocols (not assigned)
- 10 Interface – PC programming station (WinEMP)/ Palm handheld (PalmEMP2)

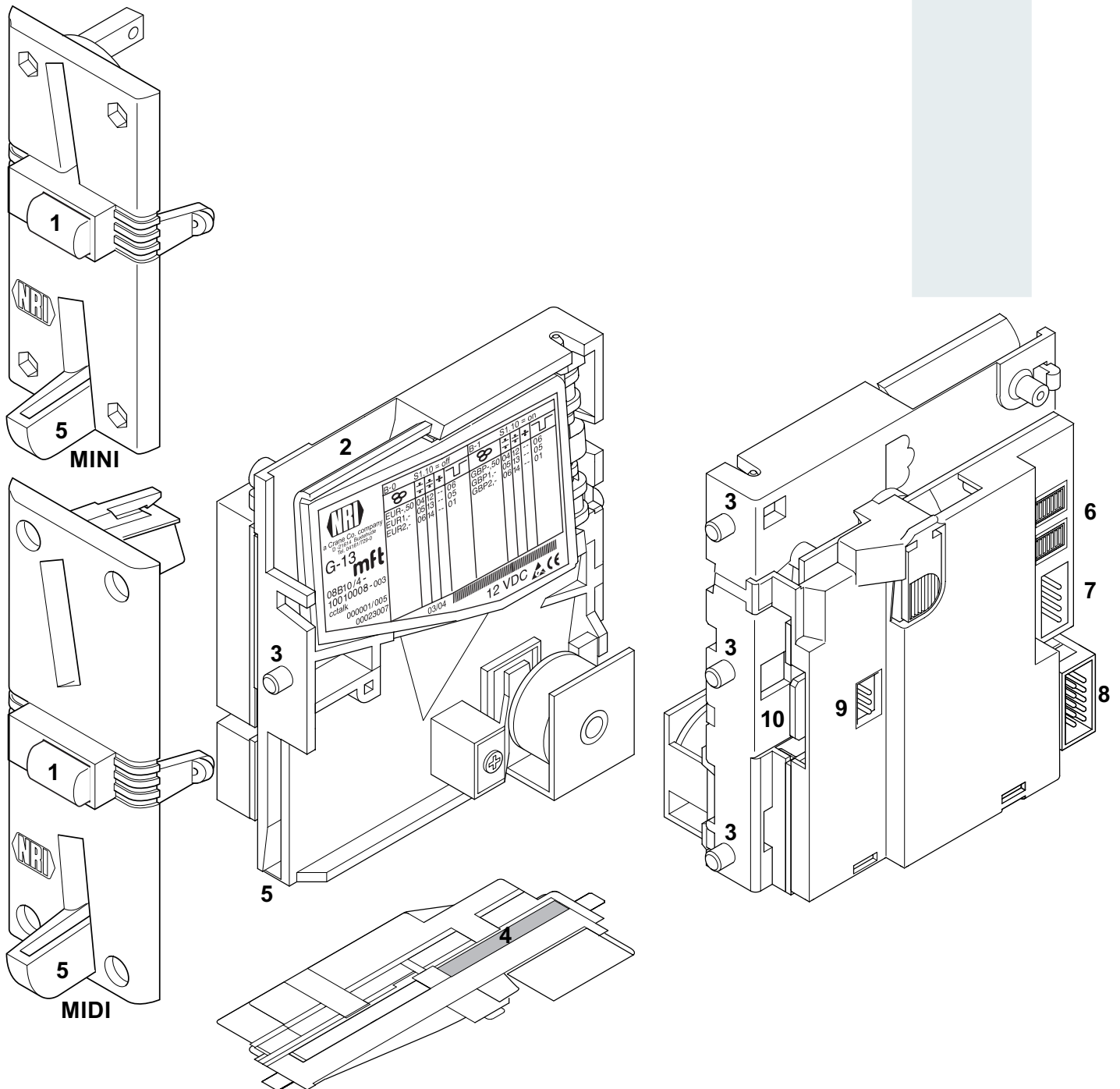

Fig. 1b: Design – G-13.mft, front entry model with front plate

- | | |
|-----------------------------|-------------------------------------------------------------------|
| 1 Return button | 7 cctalk interface – vending machine |
| 2 Coin insert funnel | 8 Interface – external sorting |
| 3 Mounting studs | 9 Interface – external sorting for other protocols (not assigned) |
| 4 Coin outlet – cash-box | 10 Interface – |
| 5 Coin outlet – return area | PC programming station (WinEMP)/ |
| 6 Switching blocks | Palm handheld (PalmEMP2) |

Coins inserted into the coin validator pass through the coin insert funnel **2** into the measurement and validation area of the device, in which their coin properties are compared with the values of the stored acceptance bands. Coins rejected by the coin validator pass into the return area **4**, Fig. 1a/5, Fig. 1b, and coins accepted for sale leave the device through the coin outlet **5**, Fig. 1a/4, Fig. 1b, and are fed into the cash-box or an external sorting device. (See Fig. 1a and 1b)

Switching blocks

On the rear side, the coin validator is equipped with two switching blocks with 10 DIL switches S1.1–10 and S2.1–10 each.

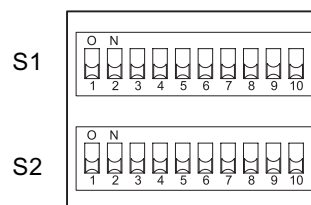

Depending on whether your device was programmed for coin data-management according to a factory-made setting for one or two memory blocks (B-0 and B-1, see label), the DIL switches will have different functions (see also section "Single or double block data-management" in Chap. 4 "Function").



On the rear side of the device you will find a brief description of the individual switch functions.

Switch assignment with double block data-management (B-0 and B-1)

Coin channels or the coin types assigned to the coin channels can be individually inhibited using the first eight DIL switches of the upper switching block S1 and the lower switching block S2 (see section "Inhibit coin channels" in Chap. 6 "Operation").

The ninth DIL switch of the upper switching block S1 does not have any function.

The tenth DIL switch of the upper switching block S1 is used to select the memory block (see section "Select memory block" in Chap. 6 "Operation").

The lower switching block S2 is used to teach coin types or tokens in the teach mode (see section "Teach mode" in Chap. 6 "Operation").

Switch assignment with single block data-management

Coin channels or the coin types assigned to the coin channels can be inhibited using the first eight DIL switches of the upper switching block S1. To do this the DIL switches are assigned a coin channel randomly. A group of selected coin channels can be assigned to a switch to inhibit a number of coin channels (see section "Inhibit coin channels" in Chap. 6 "Operation").

The ninth and tenth DIL switches of the upper switching block S1 do not have any function.

The lower switching block S2 is used to teach coin types or tokens in the teach mode (see section "Teach mode" in Chap. 6 "Operation") and to inhibit these taught coins in the normal operating mode.

Return lever and return button

The return lever (1, Fig. 1a) on the top of the device is operated using the return button on the vending machine if the coins which have already been inserted are to be returned or a jam caused, e.g., by coins which have become stuck needs to be removed. Operating the return lever opens the measurement and validation area of the coin validator so that all objects in the coin validator are transported into the return area.

Devices with front entry through a front plate do not have a return lever. Here the measurement and validation area is opened by pressing the return button (1, Fig. 1b) on the front plate.

Interfaces

In the middle on the right-hand side on the rear of the coin validator there is the 4-pole cctalk connecting plug to the vending machine and, situated below it, the 10-pole plug for connecting an external sorting device. On the left-hand side, there is an interface to the programming station or to the Palm handheld. (See Fig. 1a and 1b)

Interface – vending machine

On the rear side of the coin validator, there is the 4-pole cctalk interface **7** to the vending machine (see Fig. 1a and 1b).

The G-13.mft receives information from or transmits information to the vending machine through the cable that is used to connect the coin validator to the vending machine. The machine operates as master and the coin validator as slave.



You will find a detailed description of the serial cctalk interface with various connection diagrams in the specification "cctalk Serial Communication Protocol, Generic Specification 4.2", which is available on the Internet at "www.cctalk.org".

You will also find a list of the cctalk commands implemented in the G-13.mft in Chap. 9 "Technical data".

For further information on the assignment of the individual plugs (pins), please refer to the section "Pin assignment" also included in Chap. 9 "Technical data".

Interface – configuration (WinEMP/PalmEMP2)

To configure the coin validator the device is connected to a PC or a mobile Palm handheld. For this purpose the G-13.mft has on the right-hand side a 10-pole PCB direct plug **10** (see Fig. 1a and 1b), which can be used to connect the coin validator to the PC via a tester and card reader or to a Palm handheld (see Chap. 5 "Starting up"). The device is set by means of the configuration and diagnostics software WinEMP or PalmEMP2 (see separate software instructions).

Interface – external sorting device

A 10-pole connecting plug **8** (see Fig. 1a and 1b) is located on the rear of the device. This plug can be used to control sorting gates for sorting inserted coins (see sections "Control for external sorting of accepted coins" in Chap. 4 "Function" and "Pin assignment" in Chap. 9 "Technical data").

Label

The label of the coin validator contains all the data defining the device such as device series, device type and device operation as well as customer-specific default values such as coin type and currency:

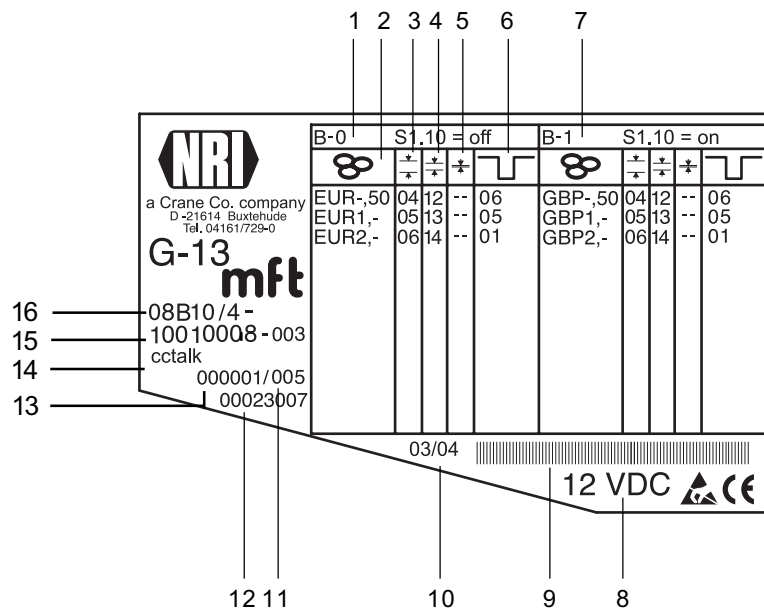

Fig. 2: Label

- | | |
|--------------------------------------------------------------------------------------|------------------------------------------------------|
| 1 Coin information – memory block 0 (if DIL switch S1.10 on OFF) | 9 Bar code |
| 2 Currency and coin type ∞ – memory block 0 | 10 Date of manufacture |
| 3 Channel number, normal coin channel $\frac{\pm}{\pm}$ – memory block 0 | 11 Consecutive device number per order number |
| 4 Channel number, narrow coin channel $\frac{\pm}{\pm}$ – memory block 0 | 12 Ordering code |
| 5 Channel number, very narrow coin channel $\frac{\pm}{\pm}$ – memory block 0 | 13 Order number |
| 6 cctalk output – memory block 0 | 14 Device model |
| 7 Coin information – memory block 1 (if DIL switch S1.10 on ON) | 15 Data block number and revision number |
| 8 Nominal voltage | 16 Device type |
- 9B = Front entry model without front plate
8B = Front entry model with MINI front plate
7B = Front entry model with MIDI front plate
6B = Top entry model

4 Function

This chapter describes how the coin validator works, using the route which an inserted coin takes in the coin validator:

- Coin acceptance and coin rejection
- Coin channels
- Single or double block data-management
- Accepted coin sensors
- Optional string recognition
- Control for external sorting device
- Inhibit coin acceptance

Coin acceptance and coin rejection

Coins inserted into the coin validator pass inductive and optical sensors which check the coins and there they generate individual measurement values. Due to the special design and arrangement of these sensors, each coin is checked for its material properties and dimensions. An upper limit and a lower limit are stored for each coin type, a so-called acceptance band so that the coin validator knows whether to accept a coin or not. If the measured values of the coin are within the acceptance band, the coin is accepted for sale when it has passed the acceptance gate and accepted coin sensors, but if they are outside the band, it is rejected and directed into the return area.

The limit values of the acceptance bands are programmed by the manufacturer according to the customers' specifications, but can be adjusted with the WinEMP PC configuration software or PalmEMP2.



Following a reset operation, the coin acceptance function is disabled and must be enabled again by the vending machine.

As a standard feature, the G-13.mft refuses each further acceptance of a coin if the G-13.mft has not been activated by the vending machine within the last 500 ms or if the last accepted coin has not yet been scanned by the vending machine.

Coin channels

The coin validator has 32 "memory slots" for coin acceptance which can be assigned up to 32 different coin types or tokens. These "memory slots" are termed coin channels. The acceptance band of a coin type/token is allocated to a coin channel and the coin type/token is accepted in that channel.

In order to reject false coins reliably, frequently for one coin type, in addition to the normal coin channel, channels with a narrow or even very narrow acceptance band are set up (see section "Label" in Chap. 3 "Design"). The limit values of these coin channels are closer to one another so that false coins with similar measured values are rejected. Narrow and very narrow coin channels, however, also possess a lower acceptance rate.

In addition, it is possible to allocate coins with different measured values but identical coin values to different coin channels. This is how the coin validator can, for example, accept old and new coins of the same type.

However, a coin channel is not only assigned the acceptance band of a coin type but also other coin information which defines further processing of the coin after its acceptance: e.g. coin value or sorting information for an external sorting device.

Since in most cases the manufacturer's customer-specific programming does not take up all the coin channels, channels which are still vacant can be assigned coin types and further information desired at any time using the WinEMP PC configuration software or PalmEMP2. Existing configurations can be changed.

The last eight coin channels 25 to 32 (or 9 to 16 with double block data-management, see section "Single or double block data-management" in this chapter) are intended to be used for the teach mode. In these coin channels new coin types can also be taught without configuration software, directly via the lower switching block on the coin validator; i.e. a coin channel is re-assigned a coin type or also a token (see section "Teach mode" in Chap. 6 "Operation").

Single or double block data-management

At the manufacturer's company, a customer-specific setting is programmed to determine whether the 32 coin channels are to be data-managed in one memory block or, when divided into 16 channels each, in two memory blocks (double block data-management).

If the double block data-management has been configured, the G-13.mft can data-manage two separately programmed (memory) blocks 0 and 1 (see label). The 16 coin channels can be assigned to each block with different coin types (also currencies), sorting information, etc. Only one block can be active at a time and be used for the coin measurement and for further coin processing. You can use the upper switching block on the device to select the desired block (see section "Select memory block" in Chap. 6 "Operation").

Accepted coin sensors

To ensure that accepted coins actually arrive in the cash-box or in an external sorting device and that coin acceptance has not been tampered with, accepted coin sensors, positioned in front of the cash-box coin outlet check whether the inserted coin drops unhindered into the cash-box chute. A coin signal is not transmitted to the vending machine until the coin has passed this checking function.

If the accepted coin sensors are continuously covered, e.g. by a coin pile-up, coin acceptance is inhibited.

Control for external sorting of accepted coins

In order to be able to guide the accepted coins into the cash-box or, e.g., into change tubes or hoppers, you can equip the coin validator with the NRI sorting device or with another sorting device.

Sorting principle

The sorting gates are activated via two sorting control lines on pins 3 and 4 of the 10-pole connecting plug on the rear of the device (see Fig. 1a and 1b).

Which coin type is to be sorted via which sorting control lines is programmed by the manufacturer according to the customers' specifications and can also be changed or re-configured with the WinEMP PC configuration software or PalmEMP2 or is set via the control system of the vending machine.



While the coin validator is sorting an accepted coin (= sorting time, see section "Sorting time of an external sorting device" in this chapter), it cannot accept any further coins unless the same cctalk sorter path is addressed.

If an external sorting device is no longer required and the sorting time is not set to zero, the coin acceptance speed will continue to be reduced by the preset sorting time. For faster coin acceptance, the sorting time should therefore be set to zero.

Sorting with NRI sorting device

When the optional NRI sorting device is used (see also section "Accessories" in Chap. 9 "Technical data"), the individual coin types can be distributed regardless of their dimensions among the three sorting chutes. Each chute can be defined as a cash-box chute.



For details on how to connect the NRI sorting device to the coin validator, see Chap. 5 "Starting up".

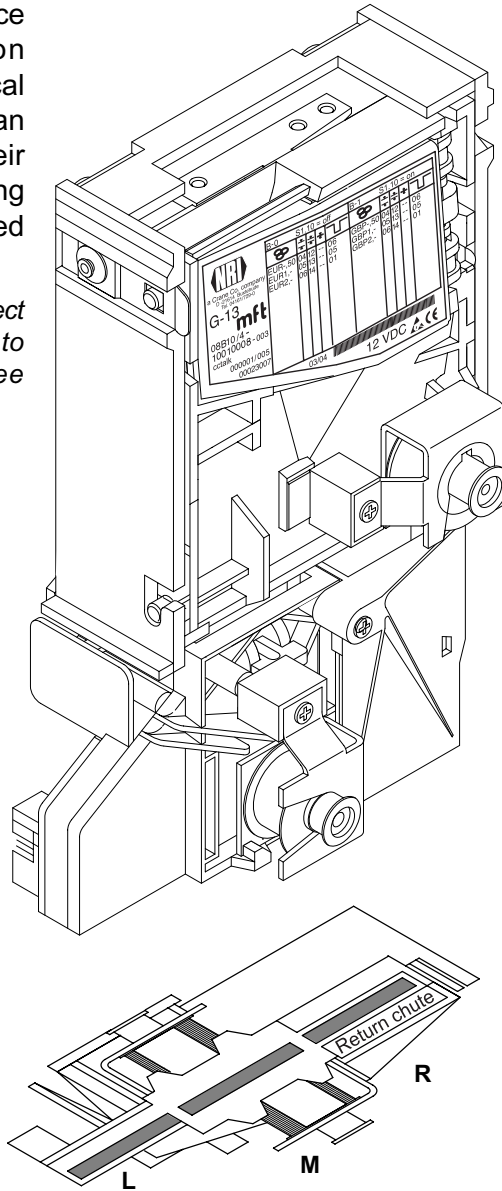

The following table shows which sorting control line must be activated in order to sort coins into a specific sorting chute and also shows which cctalk sorter path is addressed:

Sorting chute	Sorting control line	cctalk sorter path
Left	6 (pin 4)	3
Middle	–	1, 4–8
Right	5 (pin 3)	2

Sorting time of an external sorting device

For the switching time of an external sorting device, you can set a sorting time using the WinEMP PC configuration software or PalmEMP2.

Do not accept coin types

If coins are no longer to be accepted for payment at the vending machine, you can inhibit coin acceptance using either the vending machine control system or the coin validator.

Inhibit all/individual coin types via vending machine control system

The vending machine can inhibit all coin acceptance. Then the coin validator no longer accepts coins. However, the vending machine can also inhibit only specific coin types, e.g., if there is no more change in an external payout device or a coin type is very frequently replaced by false coins.

To find out how to program these functions, please refer to the specification "cctalk Serial Communication Protocol, Generic Specification 4.2", which is available on the Internet at "www.cctalk.org".

Inhibit individual coin types/coin type groups on the coin validator

As an alternative to the individual inhibiting of specific coin types using the vending machine, you can inhibit individual coin types or even groups of coin types on site using the DIL switches on the coin validator (see section "Inhibit coin channels" in Chap. 6 "Operation").



If individual coin types are to be inhibited on a long-term basis, you can use WinEMP or PalmEMP2 to deactivate the respective coin channels without being required to delete the individual configuration. This individual configuration remains available and can be reactivated again later.

5 Starting up

The G-13.mft is either

- started up in a machine, or
- connected for configuration of the device with the NRI software
 - to a PC and to an NRI tester for configuration with the software WinEMP or
 - to a Palm handheld for configuration with the software PalmEMP2 in the machine.

In the last section of this chapter, you can find out how to fit the NRI sorting device to the G-13.mft before you install the device in the vending machine.

Starting up in the vending machine

To install the G-13.mft in the vending machine with cctalk interface:

- 1** If necessary, install sorting device on the coin validator (see section "Installation of the NRI sorting device" in this chapter).
- 2** Disconnect the machine from the mains supply.
- 3** Hang the coin validator in the vending machine mount using the lateral mounting studs **1** (see Fig. 3).
- 4** Connect the coin validator to the vending machine using the 4-pole cctalk interface **3** provided and the appropriate connecting cable (see Fig. 3).
- 5** Reconnect the mains supply to the machine.



Make sure the correct supply voltage is connected (see label).

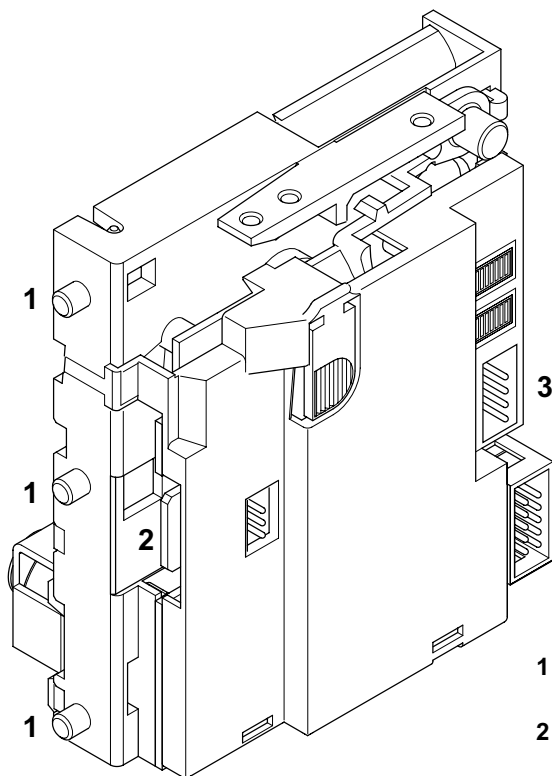

- 1** Mounting studs
(not illustrated on the left-hand side of the device)
- 2** Interface – PC programming station (WinEMP)/
Palm handheld (PalmEMP2)
- 3** Interface – vending machine

Fig. 3: Installation

Device environment for configuration software WinEMP

If you want the G-13.mft to be set on the PC using the diagnostics and configuration software WinEMP, the following device environment is connected to the PCB direct plug **2** of the coin validator (see Fig. 3 and section "Accessories in Chap. 9 "Technical data"):

- Tester G-19.0641
- Card reader G-19.0647 incl. chip card

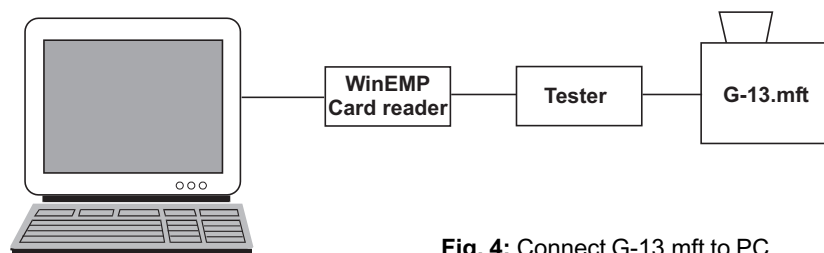

Fig. 4: Connect G-13.mft to PC

To find out how to connect this device environment to your PC, please refer to the separate operating instructions for the WinEMP software "WinEMP – The configuration and diagnostics program for NRI coin validators" (refer also to Chap. 8 "Which functions can be set using WinEMP/PalmEMP2?").

Connection to Palm handheld (PalmEMP2)

With a Palm handheld and the NRI software PalmEMP2 the G-13.mft can be directly configured on site inside the machine. The PalmEMP2 program is available on the NRI homepage. To be able to connect your Palm handheld to the coin validator, you need an NRI dongle (see section "Accessories" in Chap. 9 "Technical data"). A connecting cable is part of the scope of delivery.

Should you wish the memory blocks of the G-13.mft to be updated and for this a data block download to be performed, a WinEMP licence with PalmEMP2 download rights must be additionally ordered (see above and the section "Accessories" in Chap. 9 "Technical data"). Having done this, the new data blocks can be loaded initially into the Palm handheld, using WinEMP from your PC's internal hard disk, then from the Palm handheld into the coin validator.

To find out how to connect the Palm handheld to the PCB direct plug **2** (see Fig. 3) and how to install and operate PalmEMP2, please refer to the separate operating instructions for the software (refer also to Chap. 8 "Which functions can be set using WinEMP/PalmEMP2?").

Installation of the NRI sorting device

If you want to operate the G-13.mft with the NRI sorting device, you must install the NRI sorting device on the device as follows:

- 1** If necessary, fasten chute extension **1** with screw **2** to sorting device **3** (see Fig. 5).
- 2** Fasten mounting frame **4** by means of screws **5** and **6** to the rear of the sorting device.
- 3** Hang the coin validator by its mounting studs **7** in the mounting frame.
- 4** Use the 10-pole sorting plug **8** on the PCB **9** and on the rear of the coin validator to connect the sorting device to the G-13.mft with the help of the appropriate sorting cable.
- 5** Connect coin validator to the vending machine (see section "Starting up in the vending machine" in this chapter).

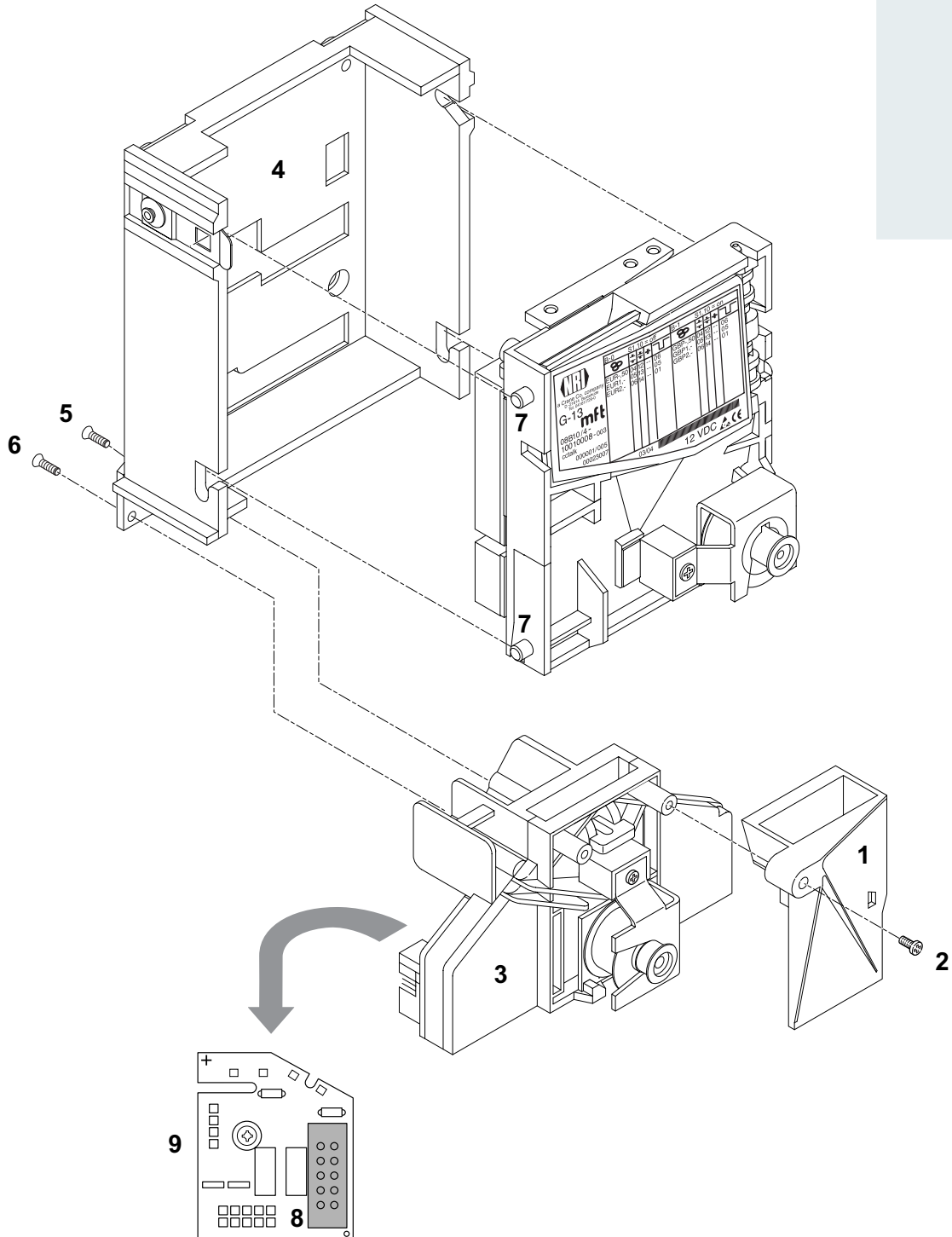

Fig. 5: Connect G-13.mft, top entry model, to NRI sorting device

6 Operation

In this chapter you will find out how to:

- Inhibit coin types or their coin channels
- Teach coin types in teach mode
- Select the desired memory block 0 or 1

Inhibit coin channels ...

Depending on whether the 32 coin channels are being data-managed in one or, when divided in 16 coin channels each, in two memory blocks (B-0 and B-1, see label), the coin types are also inhibited differently.

... with double block data-management (B-0 and B-1)

Using the first eight DIL switches of the two switching blocks S1 and S2 on the rear of the coin validator each of the 16 coin channels or each coin type assigned to a specific coin channel can be inhibited individually, i.e. this coin type is not accepted for payment on the vending machine.

The 16 DIL switches inhibit the following coin channels:

Switching block S1

DIL switch		off	on
1	Coin channel 1	vacant	inhibited
2	Coin channel 2	vacant	inhibited
3	Coin channel 3	vacant	inhibited
4	Coin channel 4	vacant	inhibited
5	Coin channel 5	vacant	inhibited
6	Coin channel 6	vacant	inhibited
7	Coin channel 7	vacant	inhibited
8	Coin channel 8	vacant	inhibited

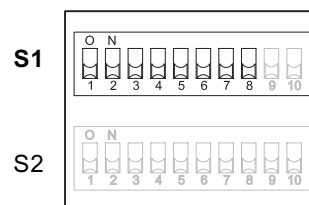

Switching block S2

DIL switch		off	on
1	Coin channel 9	vacant	inhibited
2	Coin channel 10	vacant	inhibited
3	Coin channel 11	vacant	inhibited
4	Coin channel 12	vacant	inhibited
5	Coin channel 13	vacant	inhibited
6	Coin channel 14	vacant	inhibited
7	Coin channel 15	vacant	inhibited
8	Coin channel 16	vacant	inhibited

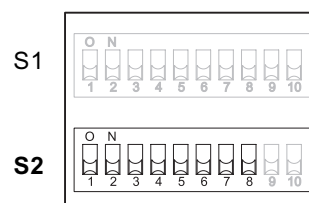

Please refer to the label of the device to see which coin type has been assigned to which coin channel at the factory. However, this assignment can be changed at any time using the WinEMP PC configuration software or PalmEMP2.

If all coin types are to be accepted for payment at the vending machine, the DIL switches S1.1–S1.8 and S2.1–S2.8 of the two switching blocks are in the lower position on OFF. If you want to inhibit a coin channel, you only need to move the respective DIL switch toward the top to ON.

Example

(the coin validator is no longer supposed to accept the coin(s) assigned to coin channels 3 and 10, which means that coin channels 3 and 10 must be inhibited)

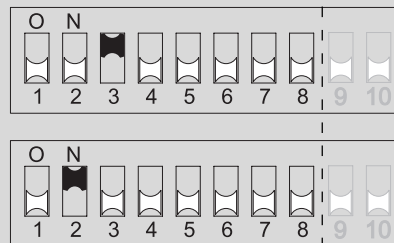

With the DIL switches in these positions, the coin validator no longer accepts the coin type(s) assigned to coin channels 3 and 10!



If a normal coin channel and a narrow coin channel have been programmed on the coin validator for one coin type, the normal coin channel must be inhibited as described above in order to activate the narrow coin channel. If both channels are activated, the wider acceptance band of the normal coin channel is used.

If a coin type is to be inhibited, both coin channels must also be inhibited.

... with single block data-management

Coin channels can be inhibited using the first eight DIL switches S1.1–S1.8 of the upper switching block on the rear of the device. To do this the DIL switches are assigned a coin channel randomly. Several coin channels can also be assigned to one switch. This switch will then inhibit a coin group (e.g. all coin channels of a currency, all coin channels of a coin type (normal and narrow coin channels)).

The assignment of DIL switches to coin type/coin group is programmed at the factory on a customer-specific basis. However, this setting can be changed with the WinEMP PC configuration software or PalmEMP2.

If all coin types assigned to the DIL switches are to be accepted for payment at the vending machine, the DIL switches must be in the lower position (on OFF).

If you want to inhibit a coin channel, you only need to move the respective DIL switch toward the top to ON.

The following examples are designed to illustrate the procedure using the label. The label shows the manufacturer's assignment of coin type/coin group.



Any coin types or tokens that may have been taught in coin channels 25 to 32 are inhibited using the DIL switches of the lower switching block S2 in the assignment according to which they were taught (see section "Teach mode" in this chapter).

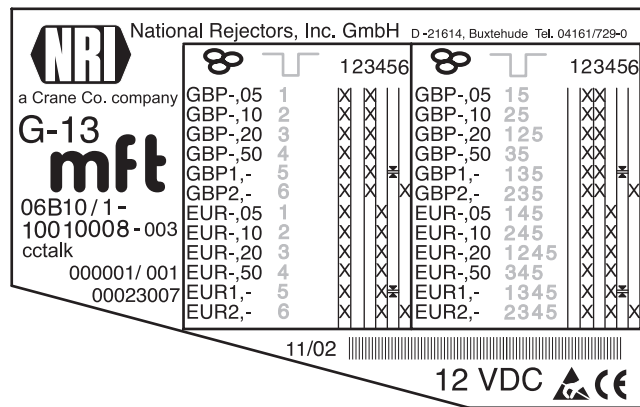

Example – Inhibit a currency as coin group X
 (the coin validator must only accept euros and no longer the British currency)



With this setting the coin validator only accepts euros.

Example – Activate narrow acceptance bands/coin channels as coin group X
 (the coin validator must accept the 1-euro coin and the British 1-pound coin in the narrow acceptance band and not in the normal one, i.e. it must inhibit the normal acceptance band)



With this setting the coin validator accepts coins in the narrow coin channel and not in the normal one.

Example – Inhibit single coin type X
 (the coin validator must no longer accept the 2-euro coin or the British 2-pound coin)



With this setting the coin validator no longer accepts the 2-euro coin or the British 2-pound coin.



At a coin validator with the label described above, it would also be possible to inhibit the euro currency via DIL switch S1.4.



With the aid of several DIL switches more than one coin type or coin group can be inhibited simultaneously.

Teach mode

Coin channels can also be taught directly without configuration software via the switching block on the coin validator, i.e. a coin channel is re-assigned a coin type or a token without having to remove the coin validator from the vending machine. You can also widen the acceptance band for the selected coin channel so that the rejection of genuine coins is reduced. For the teaching procedure, coin channels 9 to 16 of the activated memory block are available with double block data-management and coin channels 25 to 32 with single block data-management (see also section "Single or double block data-management" in Chap. 4 "Function").

Switch assignment with double block data-management (in teach mode)

Switching block S2

DIL switch		off	on
1	Coin channel 9	–	teach
2	Coin channel 10	–	teach
3	Coin channel 11	–	teach
4	Coin channel 12	–	teach
5	Coin channel 13	–	teach
6	Coin channel 14	–	teach
7	Coin channel 15	–	teach
8	Coin channel 16	–	teach
9	Teach mode	switch off	switch on
10	Acceptance band	normal	wide

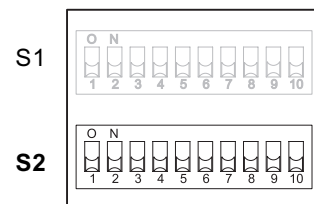

Switch assignment with single block data-management (in teach mode)

Switching block S2

DIL switch		off	on
1	Coin channel 25	–	teach
2	Coin channel 26	–	teach
3	Coin channel 27	–	teach
4	Coin channel 28	–	teach
5	Coin channel 29	–	teach
6	Coin channel 30	–	teach
7	Coin channel 31	–	teach
8	Coin channel 32	–	teach
9	Teach mode	switch off	switch on
10	Acceptance band	normal	wide

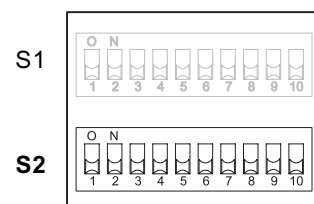

Teach coin channels

To assign a coin type to a new coin channel, please proceed as follows:



If you use the lower switching block to inhibit individual coins, remember the current switch settings so that you can restore them easily for the normal operating mode at the end.

- 1 Set all DIL switches 1–10 of the lower switching block toward the bottom to OFF.



- 2 Set DIL switch S2.9 toward the top to ON. Now the device is in teach mode to teach the coin channels.

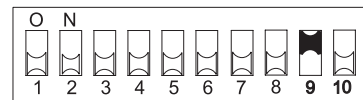

- 3 Release the coin channel to be taught (9–16 or 25–32, here: 11 or 27) by setting the appropriate DIL switch (S2.1–8, here: S2.3) toward the top to ON.



- 4 Insert at least 10 coins of the new coin type/token into the coin validator or vending machine. After the 10th coin has been inserted, the acceptance gate is operated once (solenoid attraction sound). Additional coins can be inserted.

Now you can save the measured values generated by the inserted coins in either a normal (a) or a wide (b) acceptance band. A wide acceptance band is only an appropriate choice when you only have a limited selection of coins at your disposal for the purpose of teaching tokens and would still like to program greater tolerance limits.

To save with the normal acceptance band:

- 5a) Set DIL switch S2.9 toward the bottom to OFF.

Successful saving is signalled by the acceptance gate attracting once, an error when saving is indicated by the acceptance gate attracting twice, if, for example, the acceptance band of the coins inserted and an acceptance band of an already programmed coin channel overlap.

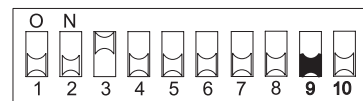

To abort the operation, first set the DIL switch of the respective coin channel (here: S2.3) and then DIL switch S2.9 toward the bottom to OFF.

To save with a wide acceptance band:

5b) Set DIL switch S2.10 toward the top to ON.

The acceptance band has been widened.

Now you can set DIL switch S2.9 toward the bottom to OFF.

Successful saving is signalled by the acceptance gate attracting once, an error when saving is indicated by the acceptance gate attracting twice, if, for example, the acceptance band of the coins inserted and an acceptance band of an already programmed coin channel overlap.



To abort the operation, first set the DIL switch of the respective coin channel (here: S2.3) as well as DIL switch S2.10 and then DIL switch S2.9 toward the bottom to OFF.

6 Set DIL switch S2.1–8 (here: S2.3) and S2.10, if necessary, for the normal operating mode (see section "Inhibit coin channels" in this chapter).

The new coin type/token will now be accepted for payment by the coin validator.



The DIL switches of the lower switching block S2 can be used to inhibit the taught coins or tokens in the assignment according to which they have been taught.

Select memory block (only for double block data-management)

If the 32 coin channels, divided in 16 coins channels each, are data-managed in two (memory) blocks (B-0 and B-1, see label), these (memory) blocks are programmed separately from one another by the manufacturer on a customer-specific basis. The data of the two blocks 0 and 1 differ when they are being used in the device, e.g. by the acceptance of different currencies, such as national currency and euro. Only one block can be active at a time and be used for the coin measurement and for further coin processing.

If the coin validator is to access the other memory block and, e.g., accept euro coins instead of national currency coins, the correct block can be selected using the upper switching block.

Set DIL switch S1.10 of the upper switching block downward to OFF to select memory block 0 and upward to ON to select memory block 1.

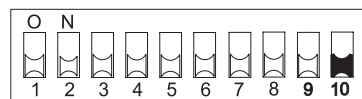

Memory block 0 selected

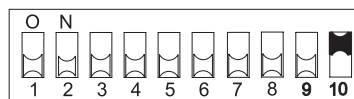

Memory block 1 selected

7 Maintenance and service

In this chapter you will find out how to

- clean the G-13.mft and
- remedy the cause of a malfunction.

Cleaning coin validator

The coin validator must only be wiped clean from time to time with a damp cloth (lukewarm water with some detergent). Beyond that, no further maintenance work is required.



Under no circumstances may the cloth be so wet that fluid runs into the device. Otherwise the PCB will be damaged. Do not use any solvents or scouring agents that will attack the plastic material of the device.

- 1** Pull the vending machine's mains plug.
- 2** Carefully open the flight deck **1** on the left-hand side and hold it open (Fig. 6).
- 3** Use a cloth to wipe off the coin runway inside the coin validator.
- 4** Close the flight deck again.
- 5** Reconnect the vending machine to the mains supply.

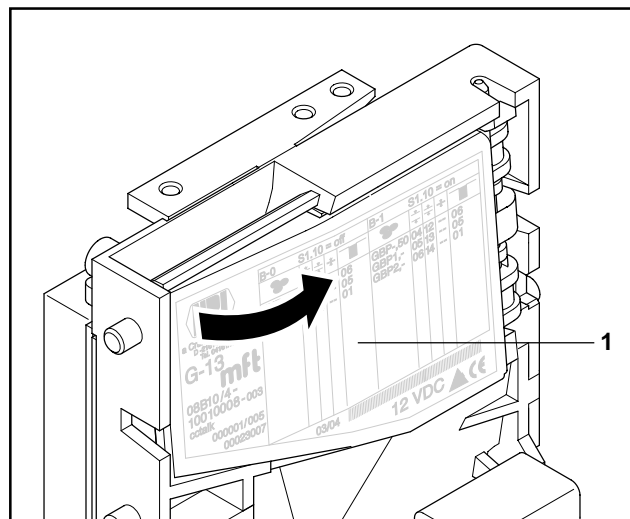

Fig. 6: Open the flight deck of the coin validator.

Troubleshooting

Malfunctions can occur in all electronic devices. These do not always have to be faults in the device. In many cases the reason is improper connections or incorrect settings. Therefore: please first of all check, whether the malfunction can simply be remedied using the following table:

Problem	Possible causes	Remedy, hints
Coin validator does not accept coin	No power supply	<ul style="list-style-type: none"> • Connect connecting cable to coin validator and vending machine correctly • Supply vending machine with voltage
	Return lever/button pressed/got stuck	Make sure, that return lever/button is not inadvertently pressed
	Coin runway dirty	Open flight deck and clean coin runway (see section "Cleaning coin validator" in this chapter)
	Coin inhibited	<ul style="list-style-type: none"> • Make sure that machine control system does not inhibit coin acceptance • Make sure that the coin is not inhibited using the DIL switches on the rear of the device or not only the narrow coin channel is enabled and the normal one is inhibited (see section "Inhibit coin channels" in Chap. 6 "Operation")
Coin validator accepts coin but no credit is given	Coin does not exit the device	Make sure that the coin outlet is not jammed by foreign objects or devices connected to the bottom of the coin validator

If the malfunction cannot be remedied, please contact our service technicians.

8 Which functions can be set using WinEMP/PalmEMP2?



To ensure that the injunctions of the Italian amusement machine law "legge 289 – comma 6" are observed, the cctalk ACMI model of the G-13.mft is not allowed to be configured. Please contact NRI if you want to change the factory settings.

The software WinEMP or PalmEMP2 is used for diagnostics purposes and for the configuration of NRI coin validators as well as for the purpose of updating the data blocks in the device memory.

WinEMP is PC software and part of a programming station for the workshop. For more information, please see the section "Accessories" in Chap. 9 "Technical data".

PalmEMP2 is software stored on a Palm handheld as additional application. If the Palm handheld is linked to the coin validator via an NRI dongle (see section "Accessories" in Chap. 9 "Technical data"), the G-13.mft can be directly configured on site inside the machine.

Both programs identify the connected coin validator and the device's own data and present them on the screen of your PC or on the Palm handheld display.

The device functions listed below can be set using WinEMP/PalmEMP2 (see separate software instructions).

- Attraction duration
- Sorting time
- Assignment
 - cctalk output – coin type
 - DIL switch – coin type (internal inhibit, only with single block data-management)
 - sorter path – coin type
- Coin acceptance band after the insertion of
 - genuine coins
 - false coins
- Teach coin channels
- Deactivate coin channels individually using coin validator software
- Data block update for current coin information



For the data block update, an additional module must be ordered in addition to the WinEMP software's basic module (see section "Accessories" in Chap. 9 "Technical data").

If you wish to perform data block updates using the Palm handheld, you need the WinEMP software with the PalmEMP2 download rights, which are stored on the WinEMP chip card (see section "Accessories" in Chap. 9 "Technical data").

9 Technical data

Supply voltage	10 V to 16 V DC
Power consumption	Standby mode: approx. 30 mA Measuring mode: approx. 100 mA Coin acceptance: approx. 100 mA + approx. 3 W
Transmitter/receiver (active low)	Inactive (H): 3.5 .. 5 V, $I_{\max} = 5 \mu\text{A}$ Active (L) : 0 ... 1 V, $I_{\max} = 30 \text{ mA}$
Temperature range	-25 °C to 70 °C
Temperature change	Max. 0.2 °C/min.
Rel. Humidity	Up to 93 %
Condensation	Not permissible
Machine interface	9600 baud, 8-bit, N, 1, 1, 5 V TTL, common transmitting and receiving line, active low Protocol in compliance with cctalk 4.2, Money Controls; For pin assignment see section "Pin assignment" in this chapter
Sorting interface	6 parallel outputs (open collector)
Coin acceptance	32 coin types max. in 2 x 16 or 1 x 32 channels Coin diameter: 15–31,5 mm (optionally up to 32.5 mm) Coin thickness: 1,5–2,5 mm (optionally bis 3.3 mm) Speed: 2 coins/sec.
Device dimensions	Height: 102 mm Width: 89 mm Depth: 52 mm (For mounting dimensions, see separate documentation)
Mounting position	Vertikal, max. deviation: $\pm 2^\circ$
Mark of conformity	CE (see next section)

CE certification

The CE certificate (CE = Communautés Européennes) confirms that our products comply with specified basic requirements of the applicable directive. The CE certificate is not a quality assurance certificate in terms of the quality expected by the manufacturer but only in terms of the quality demanded legally. It is a pure administrative certificate and is intended only as proof of compliance with the directives for the monitoring authorities and not directed at clients or final customers.



Which directives were applied can be seen in the declaration of conformity. The manufacturer must keep this declaration available for the monitoring authorities only (for a minimum period of 10 years after the last product has been introduced to the market). However, upon request we can provide copies of this declaration for our customers.

The following directives and their subsequent changes can be partially applied to our devices:

1. The EMC Directive (89/336/EEC)
for devices which cause electromagnetic interference or are interfered with by such.
2. The Low Voltage Directive (73/23/EEC)
for electrical equipment which is used with a nominal voltage of between 50 and 1000 V AC and 75–1500 V DC.
3. The CE Certificate Labelling Directive (93/68/EEC)
Modification directive regarding the application and use of CE labels.

Pin assignment

In the following sections you will find the pin assignment for the connection of the G-13.mft to the vending machine and to an external sorting device.

G-13.mft – vending machine

Pin 1	12 V DC supply
Pin 2	reserved
Pin 3	ground (GND)
Pin 4	data

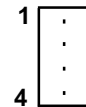

G-13.mft – external sorting device

Pin 1	ground (GND)
Pin 2	12 V DC supply
Pin 3	sorting control line 5
Pin 4	sorting control line 6
Pin 5	reserved
Pin 6	reserved
Pin 7	possible sorting control line 1
Pin 8	possible sorting control line 2
Pin 9	possible sorting control line 3
Pin 10	possible sorting control line 4

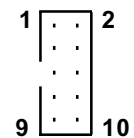

Commands, status and error messages

In the following tables you will find commands, status and error messages, which are sent to the vending machine from the coin validator and are implemented as headers in the cctalk protocol.

Implemented cctalk commands

Header	Command [bytes expected/returned]	Deviation acc. to version for Italian gambling machine market (ACMI)
254	Simple poll: [0/0]	
253	Address poll: [0/1]	
252	Address clash: [0/1]	
251	Address change: [1/0]	
250	Address random: [0/0]	
249	Request polling priority: "200 ms" [0/2]	
248	Request status: 0 = OK/ 1 = Return lever aktuated [0/1]	
246	Request manufacturer ID: "NRI" [0/3]	
245	Request equipment category ID: "Coin acceptor" [0/13]	
244	Request product code: "G-13" [0/3]	
243	Request database version: 0 (remote coin database not available) [0/1]	
242	Request serial number: 4 bytes [0/4]	3 bytes [0/3]
241	Request software revision: "xx.xx" [0/5]	
240	Test solenoids: Bit0: Gate 0, Bit1: Gate 1, Bit2: Gate 2, Bit3: Gate 3 1 = OK/0 = Error [1/0]	
236	Read opto states: 0 = OK/1 = Error [0/1]	
232	Perform self test: 0 = OK/1 = EEPROM checksum corrupt/8 = fault on sorter exit sensors [0/1]	

Header	Command [bytes expected/returned]	Deviation acc. to version for Italian gambling machine market (ACMI)
231	Modify inhibit status: [2/0]	
230	Request inhibit status: [0/2]	
229	Read buffered credit or error codes: See buffered error code table below [0/11]	
228	Modify master inhibit status: [1/0]	
227	Request master inhibit status: [0/1]	
222	Modify sorter override status: 4-way override [1/0]	1-way override [1/0]
221	Request sorter override status: [0/1]	
219	Enter new PIN number: [4/0]	
218	Enter PIN number: [4/0]	
216	Request data storage availability: 0, 0, 0, 0, 0 [0/5]	no answer
210	Modify sorter paths: 5 bytes [5/0]	2 bytes [2/0]
209	Request sorter paths: 4 bytes [1/4]	1 byte [1/1]
192	Request build code: "G01" [0/3]	"I05" [0/3]
189	Modify default sorter path: [1/0]	
188	Request default sorter path: [0/1]	
184	Request coin ID: i.e. "EU200A" = 2.00 EUR [1/6]	
4	Request comms status revision: 1, 4, 2 [0/3]	
1	Reset device: [0/0]	

Buffered error code table

1	Reject coin
2	Inhibited coin
8	2nd close coin error
10	Credit sensor not ready
14	Credit sensor blocked
16	Credit sequence error
17	Coin going backwards
20	Coin-on-String mechanism activated
24	5 rejected coins in sequence
254	Coin return mechanism activated
255	Unspecified alarm code

Standard settings (following reset)

All settings performed by the vending machine control system are transient. Following a reset operation, the following standard settings are applicable until the control system changes any settings:

Description	Value
Address	2
Inhibit status	00h 00h (all coins inhibited)
Master inhibit status	01h (not inhibited)
Sorter override status	FFh (no override)
PIN number	0 0 0 0 (PIN not used)
Sorter paths	predefined setting acc. to data block
Default sorter path	predefined setting acc. to data block

Accessories

In order to test the coin validator or adapt it to your individual needs, you can acquire the following accessories from NRI:

Front plates

For the G-13.mft two different front plates are available, which are fitted from the left-hand side to the front entry model of the coin validator, so that the cut-out in the machine wall provided for the installation is enclosed:

- MIDI front plate
 - with white return button (ordering code 5508)
 - with black return button (ordering code 19329)
- MINI front plate
 - with white return button (ordering code 22569)
 - with black return button (ordering code 23097)

Coins are inserted into the device via the top slot in the front plate. Not accepted coins that are directed into the return area are returned via the lower slot.

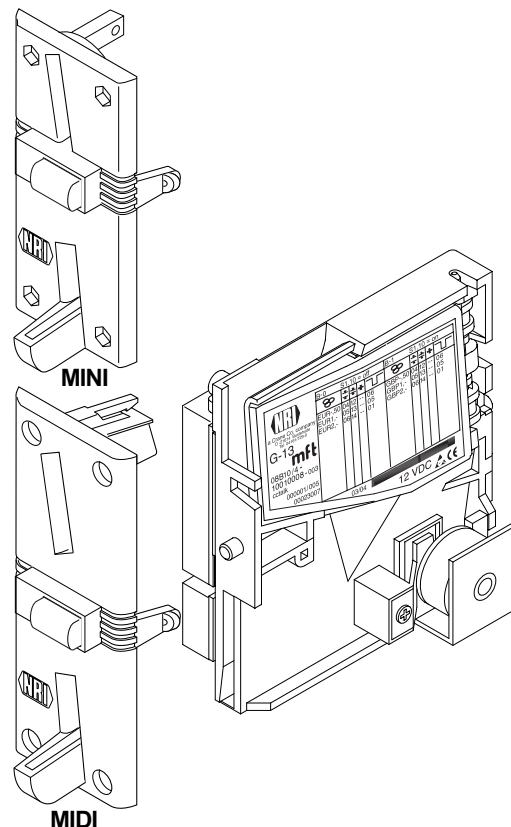

Sorting device

For the sorting of the G-13.mft (top entry model), a 3-fold sorting device is available (ordering code 26307). It is fastened using a mounting frame (ordering code 24157) to the coin validator.

For details on how to connect the sorting device, see Chap. 5 "Starting up".

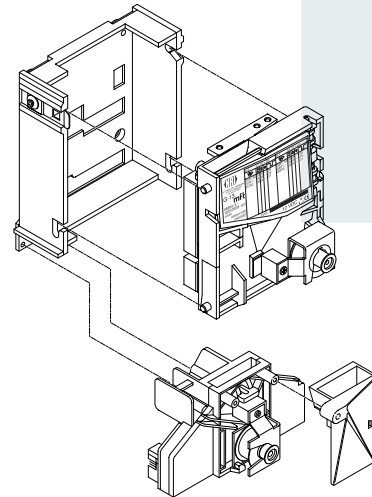

Configuration software

To be able to react as quickly as possible to new false coins, in the workshop or on site, and enable you to make your individual adjustments, the coin validator can be connected to:

- The NRI PC programming station consisting of
 - Configuration and diagnostics software "WinEMP", including card reader and chip card (ordering code 20119 for basic module and 20169 for additional module)
 - Tester G-19.0641 (ordering code 12922)
- The NRI Palm application "PalmEMP2", which is available on the NRI homepage. To be able to connect a Palm handheld m125 to the coin validator, you need a dongle with the ordering code 23760; for an m105, a dongle with the ordering code 23761. If you want to perform data block downloads with the help of a Palm handheld, you need the WinEMP software (see above) with PalmEMP2 download rights (ordering code 23649), which are saved on the WinEMP chip card.



You can also use a 9-pole D-SUB plug (ordering code 23764) to connect the Palm handheld via the universal dongle. However, the Palm handheld must be equipped with an interface that can be connected to the serial HotSync cable (available with Palm™). For further details about the individual PalmEMP2 dongles, please refer to the NRI homepage (www.nri.de).

For details on which settings can be made with the help of WinEMP and PalmEMP2, please see Chap. 8 "Which functions can be set using WinEMP/ PalmEMP2?". For details on how to carry out these settings, please refer to the separate software instructions.

Index

A

Accentuations in the text 7
 Acceptance
 band 18, 52
 gate 18, 52
 of coins 18, 40
 Speed 40
 Accepted coin sensor 20, 52
 Accessories 46
 ACMI model 9
 Advantages 9
 Amusement machine law, Italy 9
 Angle, mounting position 40
 Attraction duration 52

B

Bar code 17
 Block
 definition 52
 select (double block data-management only) 36
 single or double block data-management 20
 Buffered error code table 44

C

Cash-box 12
 cctalk
 commands 43
 specification 16
 CE
 certificate labelling directive 41
 certification 41
 Channel 19, 52
 Cleaning 37
 Coin
 acceptance 40
 band 19, 52
 channels 19, 52
 narrow 19
 normal 19
 teach 19, 34
 very narrow 19
 Diameter 40

insert funnel 12, 14
 outlet 12, 14
 properties 52
 Thickness 40
 type 17, 52
 teach 19, 34
 value 52
 Commands 43
 Condensation 40
 Configuration 39
 Connection
 Palm handheld (PalmEMP2) 27
 PC (WinEMP) 26
 vending machine 25, 28
 Conventions, instructions 7
 Currency 17
 Current consumption 40

D

Data block
 number 17
 update 27, 39, 48, 53
 Default status 45
 Design 12
 Deviation, mounting position 40
 Device
 dimensions 40
 number 17
 type 17
 Diagnostics 39
 DIL switches 14, 30
 double block data-management 14
 inhibit coins
 double block data-management 30
 single block data-management 32
 single block data-management 15, 32
 teach mode
 double block data-management 34
 single block data-management 34
 Dimensions 7, 40
 Discharge, electrostatic 11
 Documentation, additional 7
 Double block data-management 20

E

ECV 53
Electrostatic discharge 11
EMC Directive 41
Error
 messages 43
 remedy 38

F

Factory setting 45
False coins, reject 19
Flight deck, open 37
Front plate 9, 13, 46
 MIDI 9, 13, 46
 MINI 9, 13, 46
Function 18

G

Gambling machine law, Italy 9
General information
 G-13.mft 8
 instructions 7
Glossary 7, 52
Guide, chapter content 7

H

Header 43
Humidity 40

I

Inhibit
 coin channels 30
 double block data-management 30
 single block data-management 32
 coin types 23
 double block data-management 30
 single block data-management 32
Input current, receiver 40
Installation
 Palm handheld (PalmEMP2) 27
 PC (WinEMP) 26
Interface
 external sorting 12, 13, 17
 PC/Palm handheld 12, 13, 16
 vending machine 16

L

Label 17
legge 289 – comma 6 9
Low voltage directive 41

M

Maintenance 37
Malfunction, what can be done? 38
Manuals, additional 7
Manufacture date 17
Mark of conformity 40
Markings in the text 7
Measurement area 14
Memory block
 definition 53
 select (double block data-management only)
 36
 single or double block data-management 20
Models 9
Mounting
 dimensions 7
 position 40
 studs 12
Multi-frequency technology 8

N

Nominal voltage 17
Notes 7

O

Open coin validator 37
Operating voltage 40
Operation 30
Order number 17
Ordering code 17
Output current, transmitter 40

P

PalmEMP2 8
 connection 27, 48
 dongle 48
 functions 39
 ordering code 48
Pictograms in the text 7
Pin assignment
 G-13.mft – external sorting device 42
 G-13.mft – vending machine 42
Power
 consumption 40
 supply 40
Programming 39
Proper use 10

R

Receiver, input current 40
Relative humidity 40
Requests to perform an action 7
Reset status 45
Return
 area 12, 14
 button 13, 15
 lever 12, 15

S

Safety instructions 7, 10
Single block data-management 20
Sorter path 22
Sorting
 control line 53
 device
 external 14
 ordering code 47
 gates 17, 53
 time 21, 23, 53
Standard settings (following reset) 45
Starting up 24
 at the vending machine 25, 28
Status messages 43
String sensor 53
Supply voltage 40
Switching block 12, 13, 14, 30, 53
 double block data-management 14
 inhibit coins
 double block data-management 30
 single block data-management 32
 single block data-management 15, 32
 teach mode
 double block data-management 34
 single block data-management 34
Symbols in the text 7

T

Teach mode 34
 description 54
Technical data 40
Temperature
 change 40
 range 40
Tester
 device environment, PC programming station
 48
 ordering code 48
Tilt, mounting position 40
Token 54
 teach 19, 35
Top entry 9
Transmitter, output current 40
Troubleshooting 38

V

Validation area 14
Variants 9
Versions 9

W

WinEMP
 connection 26, 48
 device environment, PC programming station
 26, 48
 functions 39
 ordering code 48

Glossary

Acceptance band	A range of acceptable measured values of one → <i>coin type</i> (with specific → <i>coin properties</i>) defined by an upper and lower limit value.
Acceptance gate	The acceptance gate diverts the inserted coins into the acceptance or return area of the coin validator.
Accepted coin sensors	The accepted coin sensors are positioned in front of the cash-box coin outlet of the coin validator and check whether accepted coins fall unhindered into the cash-box chute.
Attraction duration	The attraction duration is used to specify the period of time for which the solenoid is to attract the → <i>acceptance gate</i> in order to guide the accepted coins to the cash-box or an external sorting device.
Block	→ <i>Memory block</i>
Channel	→ <i>Coin channel</i>
Coin acceptance band	→ <i>Acceptance band</i>
Coin channel	Coin channels are used to describe → <i>coin types</i> using their different → <i>coin properties</i> (alloy, size, etc.). The required coin properties of a coin type are defined in → <i>acceptance bands</i> which are assigned to the coin channels together with other coin information for further processing along.
Coin properties	Coin properties are measured when a coin is inserted into the coin validator. These are e.g. material, thickness, volume, minting, diameter, mass, hardness, etc.
Coin type	One coin type includes all coins for which the → <i>coin properties</i> agree.
Coin value	The value of a → <i>coin type</i> that is transmitted to the vending machine using the respective cctalk output 1–16.

Data block update	When updating a data block (set) (2 data blocks) using WinEMP or PalmEMP2, the data blocks for the connected coin validators are loaded quickly and easily from the internal hard disk of your PC into the coin validator. By doing this, a new data block is loaded into → <i>memory block 0</i> (and memory block 1). The new data blocks contain different configurations of → <i>coin channel</i> data e.g. current limit values of the → <i>acceptance bands</i> for a currency or new coin or sorting information.
ECV	Electronic Coin Validator
Memory block	Memory of the coin validator. At the manufacturer's company, a customer-specific setting is programmed to determine whether the 32 → <i>coin channels</i> of the G-13.mft are to be data-managed in one memory block (single block data-management) or, when divided into 16 channels each, in two memory blocks (double block data-management). Two (memory) blocks 0 and 1 can be used to data-manage two independent configurations of coin channel data (e.g. two currencies). However, for coin validator operation, only one memory block with 16 channels can be active at a time; the other block is inhibited. The memory block(s) can be updated using WinEMP or PalmEMP2 (→ <i>data block</i> download).
Sorting control line	To sort the cash-box coins with an external sorting device, the coin validator has 2 defined and 4 undefined sorting control lines.
Sorting gate	The sorting gates are activated in the coin validator depending on the run time of accepted coins and direct the coins to be sorted into the return area or coin outlet towards the cash-box or external sorting device.
Sorting time	The sorting time specifies the switching times of an external sorting device.
String sensor	The coin validator's optional sensor recognizes a coin inserted with a piece of string attached to it. The coin is not accepted for payment.
Switching blocks	The two switching blocks are located on the rear of the coin validator and incorporate 10 DIL switches each. Each switch has a specific function, e.g. inhibiting individual or grouped → <i>coin channels</i> .

Teach mode

In the teach mode, the last eight → *coin channels* can be assigned new coin types or tokens on site at the vending machine, which means that these newly configured coins are accepted in the respective coin channel.

Token

Tokens are accepted for payment at machines instead of coins in a currency.